

everything you need
to know about

Vinyl Cutting



SAIC SERVICE BUREAU

everything you need
to know about

Vinyl Cutting



SAIC SERVICE BUREAU

What's vinyl cutting?

Vinyl cutting uses a plotter to cut designs & text into adhesive material. You can make window decals, wall text for a gallery, reflective stickers, or stencils for painting.

48
hours

Vinyl Cutting takes 48 hours.

Weeding and Taping are also necessary for installation.

Please plan accordingly and allow enough time before install to weed and tape.

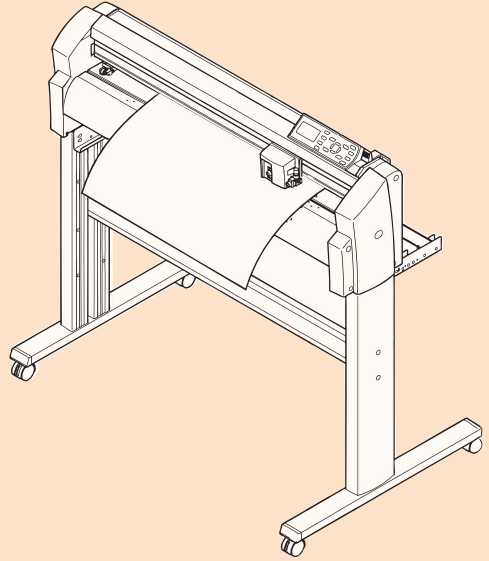

What's vinyl cutting?

Vinyl cutting uses a plotter to cut designs & text into adhesive material. You can make window decals, wall text for a gallery, reflective stickers, or stencils for painting.

48
hours

Vinyl Cutting takes 48 hours.

Weeding and Taping are also necessary for installation.

Please plan accordingly and allow enough time before install to weed and tape.

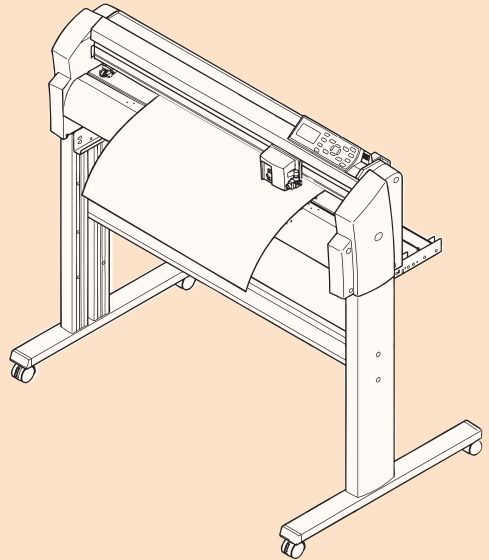

GOOD TO KNOW

We do not offer weeding or taping services, but we can show you how to do it and lend you the supplies to weed and tape the vinyl yourself.

**Supplies for weeding & taping are available for use at the Service Bureau and are to be used on the 11th floor only.*

Weeding is removing the excess vinyl that will not be applied to the final surface.

Taping means applying a low tack application tape to the front of the vinyl. This is done after weeding, and it removes the vinyl from the backing and allows you to then apply it to the wall.

To purchase supplies to take off site or to purchase your own vinyl to cut with us we recommend Sign Outlet Store.

To be safe please consult a technician before purchasing materials for cutting.

A sample book of available colors is available upon request.



GOOD TO KNOW

We do not offer weeding or taping services, but we can show you how to do it and lend you the supplies to weed and tape the vinyl yourself.

**Supplies for weeding & taping are available for use at the Service Bureau and are to be used on the 11th floor only.*

Weeding is removing the excess vinyl that will not be applied to the final surface.

Taping means applying a low tack application tape to the front of the vinyl. This is done after weeding, and it removes the vinyl from the backing and allows you to then apply it to the wall.

To purchase supplies to take off site or to purchase your own vinyl to cut with us we recommend Sign Outlet Store.

To be safe please consult a technician before purchasing materials for cutting.

A sample book of available colors is available upon request.



GUIDELINES + SUGGESTIONS

We recommend using Adobe Illustrator to build your file.

All elements of the image must be vector objects in order for the machine to see a cut line.

We recommend text is not smaller than 24pt–36pt

Serif fonts are harder to weed than sans-serif.

We will not adjust files that are submitted incorrectly.

Cut Vinyl orders are submitted via our Digital Storefront at the link below.

<https://www.sbureau.artic.edu>

Adobe Illustrator is available on the Self-Service computers around campus.



It is also available through the schools Creative Cloud application program.

If you are unsure how to download software and need assistance please visit one of the Help Desks on campus.

<http://www.saic.edu/crit/>

Illustrator tutorials:

<https://www.lynda.com>

<https://helpx.adobe.com/>

GUIDELINES + SUGGESTIONS

We recommend using Adobe Illustrator to build your file.

All elements of the image must be vector objects in order for the machine to see a cut line.

We recommend text is not smaller than 24pt–36pt

Serif fonts are harder to weed than sans-serif.

We will not adjust files that are submitted incorrectly.

Cut Vinyl orders are submitted via our Digital Storefront at the link below.

<https://www.sbureau.artic.edu>

Adobe Illustrator is available on the Self-Service computers around campus.



It is also available through the schools Creative Cloud application program.

If you are unsure how to download software and need assistance please visit one of the Help Desks on campus.

<http://www.saic.edu/crit/>

Illustrator tutorials:

<https://www.lynda.com>

<https://helpx.adobe.com/>

FILE SETUP - ILLUSTRATOR

STEP 1

File > New > Document.

The size of your document will depend on the final size of your vinyl. Since our vinyl rolls are 30" wide we recommend not making your document wider than 28".

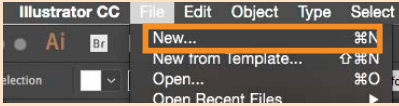

Set the width of the document to the final size of your design—**with a max of 28 inches.**

This is your cutable width.

Set the height to X number of inches. You are charged for the full artboard size so you will want to eliminate as much white space as possible.

If your design is larger than 28 inches you will need to split your design into multiple artboards, "slicing" graphics into parts if necessary.



FILE SETUP - ILLUSTRATOR

STEP 1

File > New > Document.

The size of your document will depend on the final size of your vinyl. Since our vinyl rolls are 30" wide we recommend not making your document wider than 28".

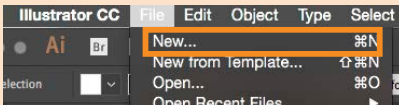

Set the width of the document to the final size of your design—**with a max of 28 inches.**

This is your cutable width.

Set the height to X number of inches. You are charged for the full artboard size so you will want to eliminate as much white space as possible.

If your design is larger than 28 inches you will need to split your design into multiple artboards, "slicing" graphics into parts if necessary.

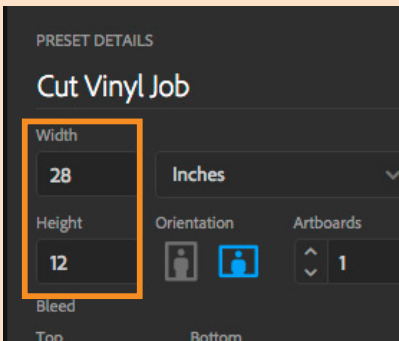

FILE SETUP - ILLUSTRATOR

STEP 2

Design or place your image/text on your Artboard.

All elements of the design must be vector objects in order for the machine to see a cut line.

All cuts are one color only.

If you wish to combine multiple colors in a vinyl application each color must be set up on separate layers or separate files.

Each color will then be cut and finally applied one color/layer at a time.



FILE SETUP - ILLUSTRATOR

STEP 2

Design or place your image/text on your Artboard.

All elements of the design must be vector objects in order for the machine to see a cut line.

All cuts are one color only.

If you wish to combine multiple colors in a vinyl application each color must be set up on separate layers or separate files.

Each color will then be cut and finally applied one color/layer at a time.



CONVERT TYPE to OUTLINES

Select all editable type in the document.

STEP 3

From the type drop down menu select the "Create Outlines" function.

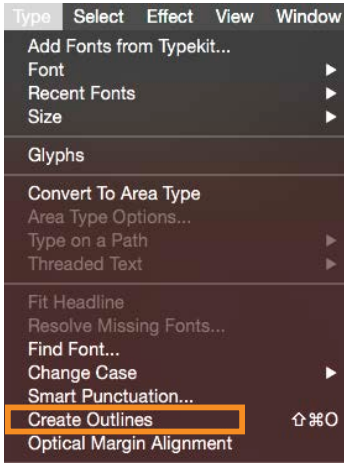

All type will be converted to vector objects with a wire frame.



CONVERT TYPE to OUTLINES

Select all editable type in the document.

STEP 3

From the type drop down menu select the "Create Outlines" function.

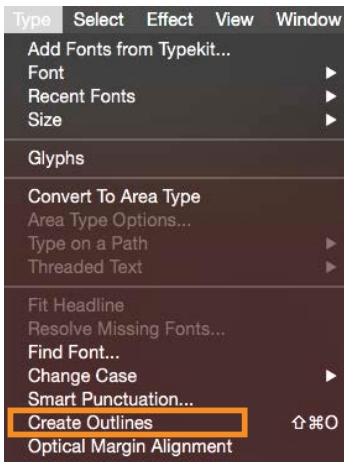

All type will be converted to vector objects with a wire frame.



OUTLINE STROKES

In order to cut a stroke it must be converted to a solid shape.

Select the stroke(s) to be outlined and click on the "Outline Stroke" function in the **Object > Path** drop down menu.

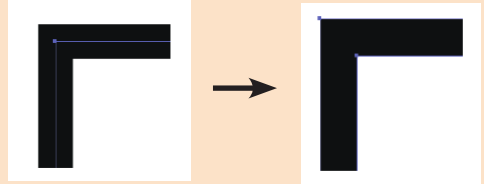
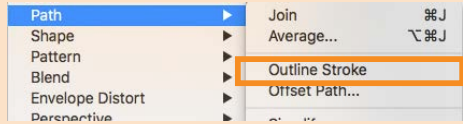

Overlapping shapes must be merged to avoid incomplete cutting.

Open the "Pathfinder" window and then select your overlapping objects.

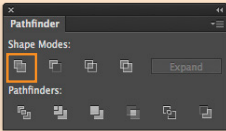

In the pathfinder window click the "Unite" function button.

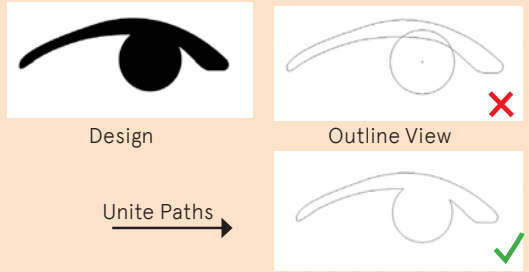

OUTLINE STROKES

In order to cut a stroke it must be converted to a solid shape.

Select the stroke(s) to be outlined and click on the "Outline Stroke" function in the **Object > Path** drop down menu.

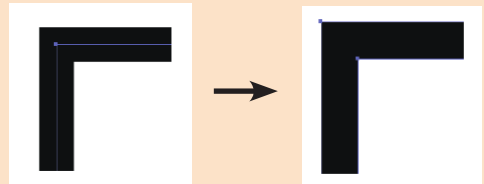
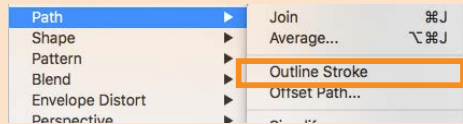

Overlapping shapes must be merged to avoid incomplete cutting.

Open the "Pathfinder" window and then select your overlapping objects.

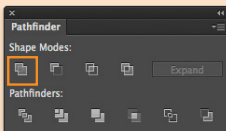

In the pathfinder window click the "Unite" function button.

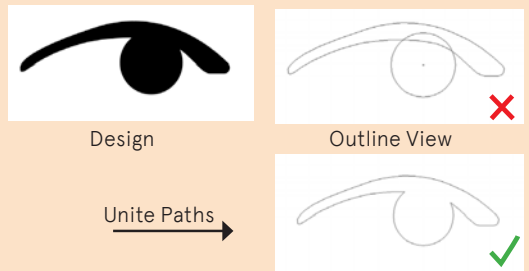

STROKES



What you see
(10 pt stroke)



What the
cutter sees



With strokes
outlined



What it should
look like

If your strokes look like this, open your Pathfinder Window, select your outlined strokes and click "Unite" under Shape Modes to unite the shapes.

If you're using Clipping Masks, go to Object > Clipping Mask > Release.

Then, with the mask shape and object selected, click exclude in the Pathfinder Window.

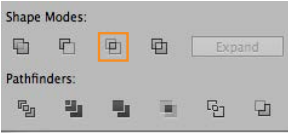

CLIPPING MASKS



What you see

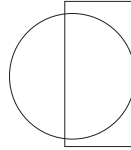

What the
cutter sees

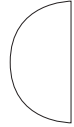

What it should
look like

STROKES



What you see
(10 pt stroke)



What the
cutter sees



With strokes
outlined



What it should
look like

If your strokes look like this, open your Pathfinder Window, select your outlined strokes and click "Unite" under Shape Modes to unite the shapes.

If you're using Clipping Masks, go to Object > Clipping Mask > Release.

Then, with the mask shape and object selected, click exclude in the Pathfinder Window.

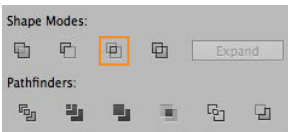

CLIPPING MASKS



What you see

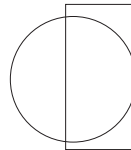

What the
cutter sees



What it should
look like

VIEW DOCUMENT AS OUTLINES

STEP 4

Select "Outline" from the view drop down menu.

Confirm there are no overlapping shapes and that all type and strokes have been outlined.

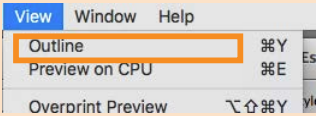

Design

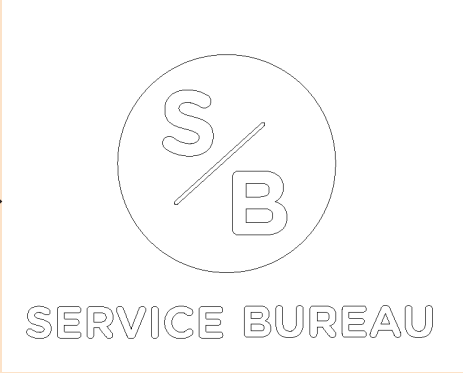

Outline View

VIEW DOCUMENT AS OUTLINES

STEP 4

Select "Outline" from the view drop down menu.

Confirm there are no overlapping shapes and that all type and strokes have been outlined.

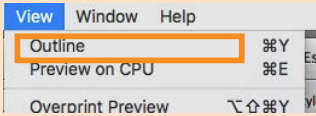

Design

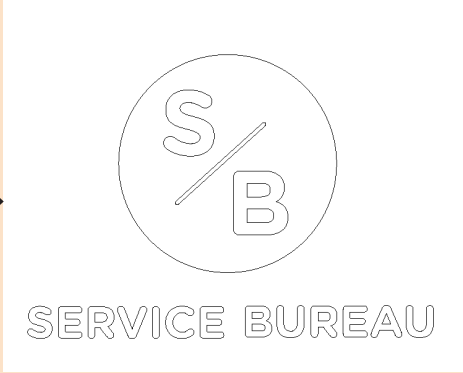

Outline View

SAVE AND SUBMIT

STEP 5

Save file in "AI" format.

Select "Save As" from the file drop down menu.

Name your file and select "Illustrator AI" format in the save as dialogue box.

Click "OK" to save.

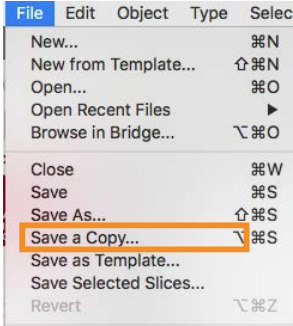

All Cut Vinyl orders are submitted via our Digital Storefront.

To get started follow these simple steps.

1. Service Bureau Online Submission (URL)

<http://sbureau.artic.edu>

2. Default Username

Your username is the same as your SAIC username.

3. Default Password

Your password is the same as your SAIC password.

Our Digital Storefront offers a quick and easy print ordering experience similar to other online retail stores that you may be familiar with.

In the next section we will briefly go over the submission process.

SAVE AND SUBMIT

STEP 5

Save file in "AI" format.

Select "Save As" from the file drop down menu.

Name your file and select "Illustrator AI" format in the save as dialogue box.

Click "OK" to save.

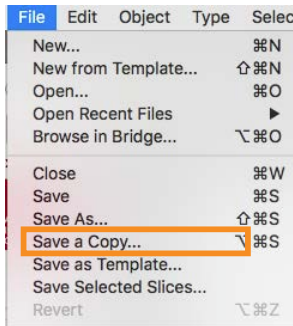

All Cut Vinyl orders are submitted via our Digital Storefront.

To get started follow these simple steps.

1. Service Bureau Online Submission (URL)

<http://sbureau.artic.edu>

2. Default Username

Your username is the same as your SAIC username.

3. Default Password

Your password is the same as your SAIC password.

Our Digital Storefront offers a quick and easy print ordering experience similar to other online retail stores that you may be familiar with.

In the next section we will briefly go over the submission process.

DIGITAL STOREFRONT

Once you have authenticated via SAIC's login page the Service Bureau's Digital Storefront will load.

Choose **Cut Vinyl** from the Product section and continue by clicking the "Begin Submission Process" button.

The next step will involve Adding Files, choosing **Media** and designating the **Final Width and Height** of your file.



Cut Vinyl

Documents Add Files

vinyl_tests.ai

* Last Name, First Name ⓘ
Bureau, Service

* Quantity * Pages
1 1

Print Options

Choose Size and Media Type ⓘ

Final Width and Height

Media(Vinyl - Light Grey)

Orientation
Landscape

If you have more than one file that is the same size and are using the same vinyl type you may upload all files into this window.

To submit multiple sizes and colors you will upload each file separately, adding that file individually to the cart.

You will then return to the Storefront to add the next file. They will all be processed together when you check out.

DIGITAL STOREFRONT

Once you have authenticated via SAIC's login page the Service Bureau's Digital Storefront will load.

Choose **Cut Vinyl** from the Product section and continue by clicking the "Begin Submission Process" button.

The next step will involve Adding Files, choosing **Media** and designating the **Final Width and Height** of your file.



Cut Vinyl

Documents Add Files

vinyl_tests.ai

* Last Name, First Name ⓘ
Bureau, Service

* Quantity * Pages
1 1

Print Options

Choose Size and Media Type ⓘ

Final Width and Height

Media(Vinyl - Light Grey)

Orientation
Landscape

If you have more than one file that is the same size and are using the same vinyl type you may upload all files into this window.

To submit multiple sizes and colors you will upload each file separately, adding that file individually to the cart.

You will then return to the Storefront to add the next file. They will all be processed together when you check out.

Print Options:

Final Width and Height will be the exact size of your artboard. This number determines the square footage and the cost of your job.

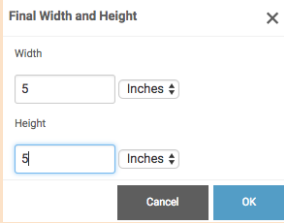

Final Width and Height

Width

5 Inches

Height

5 Inches

Cancel OK

Choose the **Media** you wish to use.

Once you have indicated the final size and media you will see the Preview of your file. (This is not an exact representation of how your file will look.)

A Pricing Summary is available at the bottom left hand side of the Preview window.

Unit Price \$5.00	Total Price \$5.00
-------------------	--------------------

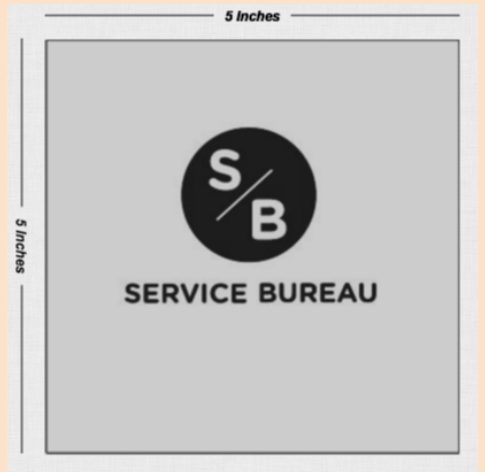

Once you are ready you can click the **Add to Cart** button you will be directed through the Checkout process.

Payment is expected when you pick up your prints at the Service Bureau. We only accept payment with ArtICard.

Print Options:

Final Width and Height will be the exact size of your artboard. This number determines the square footage and the cost of your job.

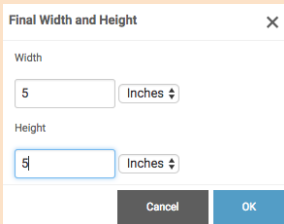

Final Width and Height

Width

5 Inches

Height

5 Inches

Cancel OK

Choose the **Media** you wish to use.

Once you have indicated the final size and media you will see the Preview of your file. (This is not an exact representation of how your file will look.)

A Pricing Summary is available at the bottom left hand side of the Preview window.

Unit Price \$5.00	Total Price \$5.00
-------------------	--------------------

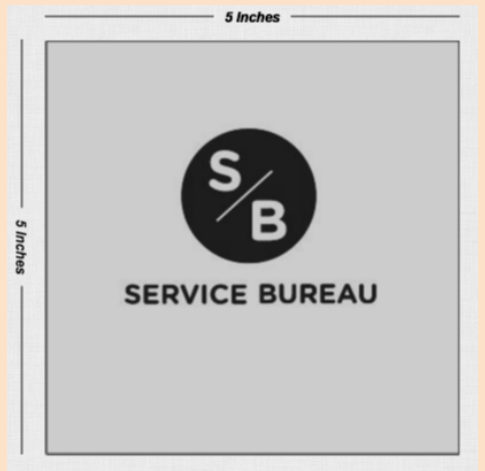

Once you are ready you can click the **Add to Cart** button you will be directed through the Checkout process.

Payment is expected when you pick up your prints at the Service Bureau. We only accept payment with ArtICard.

AVAILABLE COLORS

We carry Avery 900 Ultimate Cast Vinyl. Below are the colors we keep in stock*. We also have a variety of special order vinyl to choose from.

NORMAL VINYL \$4/sqft



Glossy Black



Glossy White



Dark Gray



Cardinal Red



Dark Yellow



Reflex Blue

Pantone

To purchase your own vinyl to cut with us we recommend Sign Outlet Store. To be safe please consult a technician before purchasing materials for cutting.

A sample book of available colors is available upon request.

AVAILABLE COLORS

We carry Avery 900 Ultimate Cast Vinyl. Below are the colors we keep in stock*. We also have a variety of special order vinyl to choose from.

NORMAL VINYL \$4/sqft



Glossy Black



Glossy White



Dark Gray



Cardinal Red



Dark Yellow



Reflex Blue

Pantone

To purchase your own vinyl to cut with us we recommend Sign Outlet Store. To be safe please consult a technician before purchasing materials for cutting.

A sample book of available colors is available upon request.

SPECIALTY VINYL \$5/sqft



Matte White
& Matte Black



Fluorescent
Magenta



Reflective
Red & White



Paintmask



Etchmark
(frosted)



Light Gray



Bayshore Blue
Pantone #292



Orange
Pantone #021



Clover Green
Pantone #354



Lavender

**Colors are just representations of available vinyl, which will look different in person. Please visit the Service Bureau to see samples of the vinyl before ordering.*

SPECIALTY VINYL \$5/sqft



Matte White
& Matte Black



Fluorescent
Magenta



Reflective
Red & White

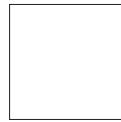

Paintmask



Etchmark
(frosted)

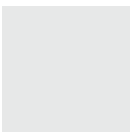

Light Gray



Bayshore Blue
Pantone #292



Orange
Pantone #021



Clover Green
Pantone #354

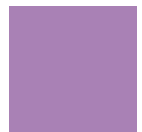

Lavender

**Colors are just representations of available vinyl, which will look different in person. Please visit the Service Bureau to see samples of the vinyl before ordering.*

Prices

	Per SqFt
Normal Vinyl	4.00
Specialty Vinyl	5.00
Customer Vinyl	3.00
Taping	Free

**CALCULATE
SQUARE FOOTAGE**

width" x height"
144



37 S Wabash
room 1111
p: 312 629 9155

e: servicebureau
@saic.edu

w: sites.saic.edu/
servicebureau

Prices

	Per SqFt
Normal Vinyl	4.00
Specialty Vinyl	5.00
Customer Vinyl	3.00
Taping	Free

**CALCULATE
SQUARE FOOTAGE**

width" x height"
144



37 S Wabash
room 1111
p: 312 629 9155

e: servicebureau
@saic.edu

w: sites.saic.edu/
servicebureau